

**CARPET CLEANING TOOLS  
& ACCESSORIES**



**WESTPAK USA**

**SOURCING SOLUTIONS - ENGINEERING**

Westpak USA entered the wand business to manufacture wands that were thoroughly engineered and designed to be the best in the industry. Our wands, hand tools, valves, and spin tools are fully designed and engineered in Garden Grove, CA, then manufactured to our exacting standards.

Many manufacturers make wands, essentially "one at a time." Each has the stainless steel pieces cut out one by one, then the bends are all made one by one. When this is done they are tack-welded together, then finish welding is done, polishing (or brushed finish), then assembled with valves, and some are tested.

At Westpak we invest extra money on full tooling for our wands. When a wand is designed and approved for production it will be another few months to actually start the production process. Complete tooling is made for each part. A custom tool is also made for each part to make all the bends. This process, while expensive, insures that each part will be made exactly the same from the first wand to the last wand.

Each wand is designed with overlapping tubes at the s-bend tube connection to the head. This provides extra strength to take the many hours of stress that this wand is designed for. Each wand is fully welded with TIG process to ensure clean defect free welds. Our wands are fully polished. Polishing does two things. First it enhances the appearance and makes the wands easier to keep clean. Polishing also increases the surface hardness of the steel and makes it more difficult for welds to crack or damage to occur. So now we have made a structurally sound wand, with excellent appearance and strength.

We now couple this wand with the best control valves in the industry, full stainless steel solution lines, manifolds, and spray bars, with properly sized and positioned nozzles and the wand is ready for full quality testing with water under pressure. Each wand is tested for defects, leaks, valve operation, and nozzle spray pattern.

Westpak USA, Inc. manufactures wands, detail tools, hard surface tools, valves, fittings, hose reels, and sprayers for the carpet cleaning industry.

**PORTABLE / BLASTER WANDS**

**3-4**



**TITANIUM / TRUCKMOUNT WANDS**

**5-6**



**DETAIL / STAIR TOOLS**

**7-8**

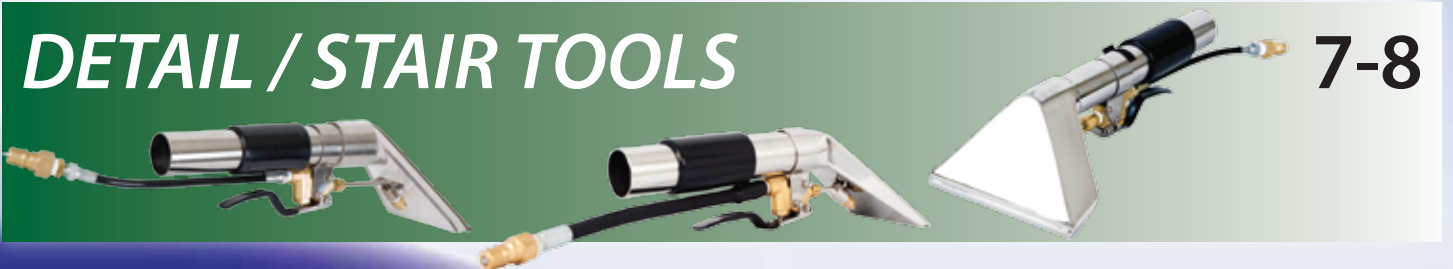

**HARD SURFACE / SPRAYERS**

**9-10**



**MOTORS / HOSES**

**11-12**



**ACCESSORIES**

**13-16**



# CLEANING WANDS

## Standard Features: 1.25 and 1.50 Inch Tube Wands

- High Pressure 'Soft-Touch' Valve • Ergonomic Grip Handle • Full Flow Vacuum Extraction • Precision Nozzles
- Polished Stainless Steel • Stainless Steel Solution Line (or High PSI Hose) • 1200+ PSI • Up to 5 Wands / Box

### Two-Piece Wands (10-1420 and 10-1428)



- 10" or 12" Head
- 1.25" (Fits 1.50" Hose) and 1.50" Tube
- Weight: 6 Lbs.
- Height: 60"
- Brass Valve
- 1/4" 110015 Nozzle
- Fits in Small Box for Cost Effective Shipping

### 10-0761 / 10-0780 / 10-0795 (1/2 Jet Wand)



- 12" Head
- 1.50" Tube
- Weight: See Last Page
- Height: See Last Page
- Brass Valve
- Nozzle: See Last Page

### Classic Style Wands (10-0780 and 10-0762)



- 12" Head
- 1.50" Tube
- Weight: 7.8 Lbs. (0762)
- Weight: 7.6 Lbs. (1455)
- Height: 62" (0762)
- Height: 60" (1455)
- Brass Valve
- 1/8" 11003 Nozzle (0762)
- TJet 11002 Nozzle (1455)

### Low Profile 1.50" Wands



- (P/N: 10-0070, 10-0530, 10-0556)
- 12" and 14" Heads
- 1.50" Tube
- Weight: 7.2 - 9.2 Lbs.
- Height: 62"
- Brass Soft Touch Valve
- 2-4 Brass Precision Jets

Low Profile  
Angled Jets for  
Shearing Action

Wand Accessories  
for more information  
turn to page 13.



Teflon Guard



VJet or TJet Nozzles



1/4" Inline Filter



Check Valves



**Standard Features: Hard Surface Wands**

- High Pressure 'Soft-Touch' Valve • Ergonomic Grip Handle • Full Flow Vacuum Extraction • Precision Nozzles
- Polished Stainless Steel • Stainless Steel Solution Line (or High PSI Hose) • 1200+ PSI • Up to 10 Wands / Box

<b>Blaster Hard Surface Wands</b>	
<b>Part #</b>	<b>Description</b>
<b>10-1542</b>	Blaster Brush Hard Surface Wand
<b>10-1544</b>	Blaster Squeegee Hard Surface Wand
<b>10-1543</b>	Blaster Wand Tube Replacement (No Head)
<b>10-1524</b>	Brush Wand (Dry Wand)
<b>10-1526</b>	Squeegee Wand (Dry Wand)
<b>10-1537</b>	Blaster Wand Tube (Dry No Head)

**NEW Interchangeable Brushes and Squeegees**  
**Interchangeable Heads**  
**Wet and Dry Versions**



Now with a 6" Interchangeable Head

<b>BLASTER REPLACEMENT PARTS</b>			
<b>Part #</b>	<b>Description</b>	<b>Part #</b>	<b>Description</b>
<b>10-0838</b>	QD Male 1/8" Straight Thru	<b>10-1564</b>	Brush Replacement Insert (Hard)
<b>10-0839</b>	QD Female 1/8" Straight Thru	<b>10-1538</b>	Head (Fitted for Nozzles)
<b>10-1551</b>	Squeegee Hold Down Strip	<b>10-1539</b>	Squeegee Head (Fitted for Nozzles)
<b>10-1553</b>	Squeegee Blade, Clear Non Marking	<b>10-1534</b>	Brush Head (Dry, No Nozzle Slots)
<b>10-1548</b>	Brush Replacement Insert (Soft)	<b>10-1536</b>	Squeegee Head (Dry, No Nozzle Slots)
<b>10-1563</b>	Brush Replacement Insert (Medium)	<b>10-1525</b>	6" Brush Grout Brush Head (Single Jet)



Solution Hose



Quick Disconnects



Valves



Valve Repair Kit

# CLEANING WANDS

## Standard Features: 1.75 or 2.00 Inch Tube Wand

- High Pressure 'Soft-Touch' Valve • Ergonomic Grip Handle • Full Flow Vacuum Extraction • Precision Nozzles
- Polished Stainless Steel • Stainless Steel Solution Line (or High PSI Hose) • 1200+ PSI • Up to 5 Wands / Box

### 1.75" & 2.00" TM & High Pressure Portables Wands

Part #	Tube Size	Head Width	Jets	Jet Size	NPT Size	Valve	PSI Rating	Weight Lbs.
10-0535	1.75"	12"	4	95015	1/8"	Brass	1200	9.4
10-0549	1.75"	14"	4	95015	1/8"	Brass	1200	9.75
10-0755	2.00"	12"	4	95015	1/8"	Stainless	1500	9.5
10-0550	2.00"	14"	4	95015	1/8"	Stainless	1500	9.8



4-Jet Low Profile Configuration



High Pressure / Gas Pump Handle



### 2.00" TM High Pressure (Gas Pump Handle) Wands

Part #	Tube Size	Head Width	Jets	Jet Size	NPT Size	Valve	PSI Rating	Weight Lbs.
10-0754	2.00"	12"	4	95015	1/8"	Stainless	1500	10
10-0750	2.00"	14"	4	95015	1/8"	Stainless	1500	10.2

Wand Accessories  
for more information  
turn to page 13.



Teflon Guard



VJet or TJet Nozzles



1/4" Inline Filter



Check Valves

# TITANIUM

## Standard Features: Titanium

- High Pressure 'Soft-Touch' Valve • Ergonomic Grip Handle • Full Flow Vacuum Extraction • Precision Nozzles
- Polished Titanium • Stainless Steel Solution Line (or High PSI Hose) • 1200+ PSI • Up to 5 Wands / Box
- Inline Filter • Stainless Steel QD • Stainless Steel Jets • 1/2" No Drip Check Valves

### 1.50" and 2.00" Titanium Wands

Part #	Tube Size	Head Width	Jets	Jet Size	NPT Size	Valve	PSI Rating	Weight Lbs.
10-5070	1.50"	12"	4	95015	1/8"	Stainless	1500	6.5
10-5755	2.00"	12"	4	95015	1/8"	Stainless	1500	7.5
10-5550	2.00"	14"	4	95015	1/8"	Stainless	1500	7.5
10-5750	2.00"	14"	4	95015	1/8"	Stainless	1500	7.8



Solution Hose



Quick Disconnects



Valves



Valve Repair Kit

# DETAIL / STAIR TOOLS

## Detailer Standard Features

- High Pressure Brass Valve • Smooth 4" Wide Design • Precision Nozzles • 10" Solution Hose • Vinyl Heat Covers

### 10-0520 (Standard Detailer)

- 4" Head
- 1.50" Tube
- Weight: 1.6 Lbs.
- Length: 11"
- Brass Valve
- 1/8" 9503 Nozzle



### 10-0521 (Splashguard Detailer)

- 4" Head
- 1.50" Tube
- Weight: 1.6 Lbs.
- Length: 11"
- Brass Valve
- 1/8" 9503 Nozzle



### 10-0506 (Low Profile Detailer)

- 4" Head
- 1.50" Tube
- Weight: 1.7 Lbs.
- Length: 11"
- Brass Valve
- 1/8" 9503 Nozzle



### 10-0524 (Short Upholstery Tool)

- 4" Head
- 1.50" Tube
- Weight: 1.6 Lbs.
- Length: 11"
- Brass Valve
- 1/8" 9503 Nozzle

Also available with  
Splashguard (10-0945)



### 10-0498 (Crevice Tool)

- 2" Head
- 1.50" Tube
- Weight: 2.0 Lbs.
- Length: 18"
- Brass Valve
- 1/8" 9503 Nozzle



### 10-0504 (Plastic Head Detailer)

- 4" Head
- 1.50" Tube
- Weight: 1.6 Lbs.
- Length: 11"
- Brass Valve
- 1/8" 9503 Nozzle



Tool Accessories  
for more information  
turn to page 13.





**Stair Tool Standard Features**

- High Pressure Brass Valve • Smooth Design • Precision Nozzles • Comfort Grip Steel Handle

**10-1322 (6" Detailer w/Vacuum Release)**

- 6" Head
- 1.50" Tube
- Weight: 2.5 Lbs.
- Length: 11"
- Brass Valve
- 1/8" 9503 Nozzle



**Optional Hose in Hose Configuration**

Hose in a Hose Setup  
or External Hose Setup  
10-1346 - 1.50" x 10' Long Hose  
10-1348 - 1.25" x 10' Long Hose



**10-0772 (Wide Stair/Detail Tool)**

- 10" Head
- 1.50" Tube
- Weight: 4.2 Lbs.
- Length: 18"
- Brass Valve
- 1/4" 9503 Nozzle

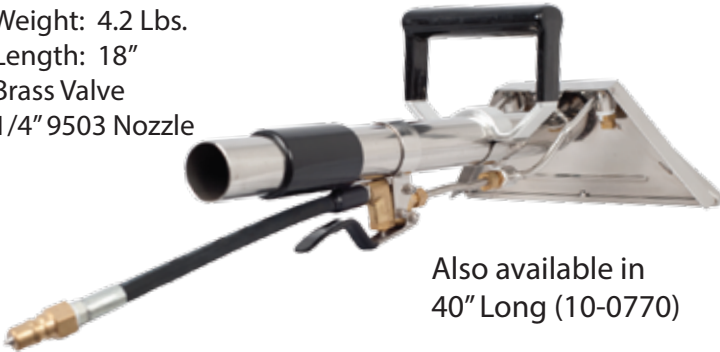

Also available in  
40" Long (10-0770)

**10-1321 (2-Jet Straight Tools)**

- 6" Head
- 1.50" Tube
- Weight: 4.8 Lbs.
- Length: 24"
- Brass Valve
- 1/8" 9503 Nozzle

Also available in  
18" Long (10-1320)

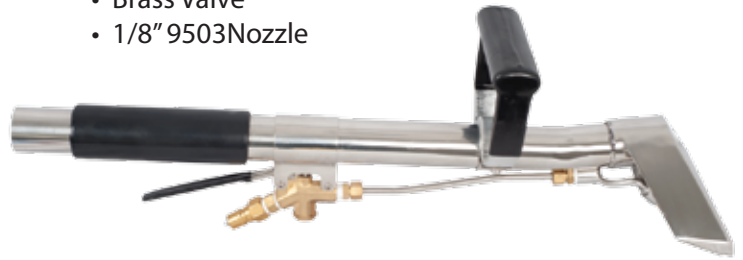

**10-0564 (2-Jet Two-Bend Long Stair Tool)**

- 10" Head
- 1.50" Tube
- Weight: 6.2 Lbs.
- Height: 40"
- Brass Valve
- 1/4" 9503 Nozzle
- 10-0567 Swivel



**10-0771 (2-Jet Two-Bend Short Stair Tool)**

- 10" Head
- 1.50" Tube
- Weight: 5.5 Lbs.
- Height: 29"
- Brass Valve
- 1/4" 9503 Nozzle

Also available in  
2.00" Tube (10-0771-2)



Solution Hose



Quick Disconnects



Valves



Valve Repair Kit

# HARD SURFACE / SPRAYERS

## Hard Surface Tools

### 20-0440 (12" Wide Hard / Tile Surface Tool)

- 12" Head
- 1.75" Tube
- Weight: 16 Lbs.
- Height: 52"
- SS Valve
- 1/8" 0502 Nozzle
- Brush Attachment
- Vacuum Relief Valve
- 3" Low Profile Head

Now Including the Brush Attachment!

Improved Spray Bar Assembly with Adjustable Nozzles!



\* Recommend Working Pressure 800 - 1200 PSI

### 20-0444 (Commercial Grade Hard Surface Countertop / Tile Tool)

- 6" Head
- 1.50" Tube
- Weight: 4.3 Lbs.
- Height: 10"
- SS Valve
- 1/8" 0502 Nozzle
- 18" Hose w/Male QD
- Replaceable Brush
- Vacuum Relief Valve
- 2.75" Low Profile Head
- Optional Hose-in-Hose



\* Recommend Working Pressure 800 - 1200 PSI

Spinner Accessories for more information turn to page 13.



Nozzles



Filter



Solution Hose



Quick Disconnects



Valves



Valve Repair Kit

Sprayers

**10-0507 (9:1 Flex Sprayer)**

- Weight: 5 Lbs.
- 45" Flex hose
- Brass Valve
- 1/4" 6506 Nozzle
- 5 Quart Upright Jug



\* Suggested Working Pressure 200 PSI  
 \*\* Suggested Temperature Rating <180°F

**10-0518 (9:1 Straight Sprayer)**

- Weight: 4 Lbs.
- 22" Straight Lance
- Brass Valve
- 1/4" 6506 Nozzle
- 5 Quart Upright Jug



\* Suggested Working Pressure 200 PSI  
 \*\* Suggested Temperature Rating <180°F

**10-0712 (Sprayer Complete Repair Kit)**

- 4:1 Metering Block
- Comes with 9:1 Tip
- Aluminum Cap
- Short Hose with Filter
- All Required Seals
- Venturi Valve
- Used with 10-0504 and 10-0518
- (Assembly includes 10-0710)



**10-0710 (Sprayer Basic Repair Kit)**

- Venturi Tip
- 9:1 Fixed Tip
- Teflon Seals
- EPDM O-Rings
- SS Ball
- SS Spring
- Used with 10-0507 and 10-0518



Sprayer Bottle

# MOTORS / PUMPS / HOSES



Pumps	Order #	Description	
	20-0616	Pump, 100 PSI, SW150 BP	
	20-0624	Pump, 120V 200 PSI, Pumptec	
	20-0627	Pump, 120V 400 PSI, Pumptec	
	20-0629	Pump, 120V 500 PSI	
	20-0640	Hard Surface Pump Set, 1200 PSI, 120 V, Adjustable	



3 Stage Motors	Order #	Description	Voltage	Watts	CFM	Lift	Air Watts
	10-2450	120V 3 Stage 5.7" Tangential Discharge Motor	120V	1500	104	137"	530
	10-2451	240V 3 Stage 5.7" Tangential Discharge Motor	240V	1500	105	137"	530
	10-2470	Discontinued					
	10-2471	Discontinued					



2 Stage Motors	Order #	Description	Voltage	Watts	CFM	Lift	Air Watts
	10-2460	120V 2 Stage 5.7" Tangential Discharge Motor	120V	1100	102	97"	351
	10-2461	240V 2 Stage 5.7" Tangential Discharge Motor	240V	1100	102	97"	351
	10-2465	120V 2 Stage 5.7" Radial Bypass Motor	120V	1100	91	65"	100
	10-2468	120V 2 Stage 5.7" Flow Thru Motor	120V	1100	109	101"	385
	10-2473	Discontinued (24V and 36V Motors)					



Motor Accessories	Order #	Description	
	10-2475	120v and 240v Motor Brushes (set of 2, replace every 500 hours)	
	10-2477	24v and 36v Motor Brushes (set of 2, replace every 500 hours)	
	20-0668	5.7" Motor Gasket with Adhesive Back	



Straps & Adapters	Order #	Description	
	10-0065	1.5" x 1.5" Hose Connector w/Vacuum Release	
	10-0066	1.5" Wye Connector w/Vacuum Release	
	10-0088	2.0" Wye Connector	
	10-0101	2.5" x 2.0" Wye Connector	
	10-0664	Wide Hose Strap w/Hook and Velcro	
	10-0665	Hose Strap w/Buckle and Velcro	



Vacuum Hoses	Order #	Description	
	10-1348	1.25" x 10' Vacuum Hose w/External Solution Hose	
	10-1346	1.5" x 10' Vacuum Hose w/Hose in a Hose	
	10-0993	1.5" Vacuum Hose, Grey 25' (Also in Blue and Orange)	
	10-0994	1.5" Vacuum Hose, Grey 50' (Also in Blue and Orange)	
	10-0995	2.0" Vacuum Hose, Grey 50' (Also in Blue and Orange)	





Barbs & Hose Cuffs	Order #	Description	
	20-0183	1.50" Grey Hose Cuff	
	20-0180	1.50" Grey Hose Cuff w/Side Inlet	
	10-0988	1.50" Grey Hose Swivel Cuff	
	10-0999	2.00" Grey Hose Cuff	
	10-1041	2.00" Grey Hose Swivel Cuff	
	10-1442	2.50" Grey Hose Cuff	
	10-0989	2.00" to 1.50" Grey Hose Cuff Reducer	
	10-0997	1.25" to 1.50" Grey Hose Cuff Expander	
	10-0986	1.50" to 2.00" Grey Hose Cuff Expander	
	10-0987	1.50" to 1.50" Grey Hose Threaded Coupler	
	10-0510	1.50" x 1.50" Grey Barb Coupling	
	10-0511	2" x 2" Grey Barb Coupling	
	10-0512	2" x 1.50" Grey Barb Coupling	
10-1449	1.50" Cuff x 2.00" SS Tube (Stair Tool Cuff Adapter)		





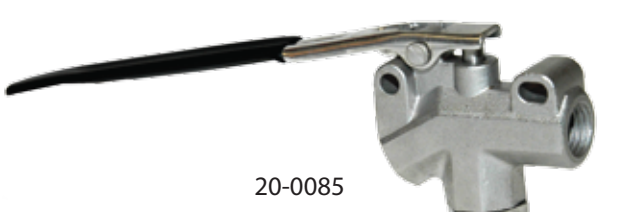





Solution Hose	Order #	Description	
	10-1364	Blue Hose w/QD's 1/4" x 25' 3000 PSI	
	10-1365	Blue Hose w/QD's 1/4" x 50' 3000 PSI	
	10-1366	Blue Hose w/QD's 1/4" x 100' 3000 PSI	
	10-1360	Blue Hose w/Crimps 1/4" x 25' 3000 PSI	
	10-1361	Blue Hose w/Crimps 1/4" x 50' 3000 PSI	
	10-1362	Blue Hose w/Crimps 1/4" x 100' 3000 PSI	
	10-1363	Blue Hose Bulk 1/4" 3000 PSI Wire Braided	
	10-1371	Black Hose w/Crimps - 1/4" M x 1/8" M - Detail Tool Hose	
	10-1372	Black Hose w/Crimps - 1/4" M x 1/4" M - Wand Hose	
	10-2604	Black Hose w/Crimps - 1/4" x 25' 3000 PSI Flex Hose	
	10-2605	Black Hose w/Crimps - 1/4" x 50' 3000 PSI Flex Hose	

Solution Accessories	Order #	Description	
	10-0026	CRS Cad Plated Crimp Fitting 1/4" Hose x 1/4" M	
	10-0677	CRS Cad Plated Crimp Fitting 1/4" Hose x 1/4" F	
	10-1063	SS Crimp Fitting 1/4" Hose x 1/4" M	
	10-1375	CRS Cad Plated Crimp Fitting 4mm Hose x 1/8" M	
	10-1376	CRS Cad Plated Crimp Fitting 4mm Hose x 1/4" M	
	10-0022	Vinyl Hose Relief 1/4"	
	10-0023	Vinyl Hose Relief 3/8"	

# ACCESSORIES





## Wand and Tool Accessories







Valves	Order #	Description
<p>The Industry's #1 Soft-Touch Valve Soft Opening Control Valve</p>      	20-0001	Detail Tool Offset Valve
	20-0030	Brass Soft Touch Angle Valve
	20-0085	SS Soft Touch Angle Valve
	20-0022	Brass 200 S Valve
	20-0018	Detail Tool Repair Kit
	20-0019	Angle Valve Repair Kit
	20-0059	Valve Mount Adapter Kit





Wand Repair and Upgrades	Order #	Description
          	10-0013	1.50" Tube Bracket for Angle Valve
	10-0019	1.75" Tube Bracket for Angle Valve
	10-0020	2.00" Tube Bracket for Angle Valve
	20-0011	1.50" Tube Bracket for Detail Valve
	10-1315	1.50" Steel Wand Handle w/Vinyl
	10-1311	1.75" Steel Wand Handle w/Vinyl
	10-1312	2.00" Steel Wand Handle w/Vinyl
	10-0501	12" Wand Repair Lip (1ea. Req. Welding)
	10-0539	14" Wand Repair Lip (1ea. Req. Welding)
	10-1190	Bypass Assy (Valve not included)
	10-0890	Teflon Guard for 12" Classic Wands
	10-0891	Teflon Guard for 12" LP Wands
	10-0893	Teflon Guard for 14" LP Wands
	20-0186	High Pressure WP Handle No Valve
20-0185	High Pressure WP Handle w/SS Valve	
20-0188	High Pressure WP Handle w/Brass Valve	
10-1055	Compression Fitting 1/8" x 3/16" Tube	
10-1063	Compression Fitting 1/8" x 1/4" Tube	





Spinner / Sprayer Repair	Order #	Description
   	20-0142	Spinner Brush Attachment
	20-0124	Spinner Delrin Ring
	20-0098	Replacement Bearing for 20-0440
	20-0155	Replacement Bearing for 20-0444
	10-0663	5 Quart Sprayer Bottle

Visit [www.westpakusa.com](http://www.westpakusa.com) for a full line of wand and other repair items.

Ball Valves					Order #	Description
					10-1000	Brass 1/4" Ball Valve FxF HD
					10-1001	Brass 3/8" Ball Valve FxF HD
					10-1012	Chrome 1/4" Ball Valve MxF
					10-1015	Chrome 1/4" Ball Valve FxF
					10-1032	Brass 1/4" Ball Valve MxF
					10-1031	Brass 1/8" Ball Valve MxF

Quick Disconnects							Order #	Description
							10-0008	1/4" FNPT x Female QD Brass
							10-0009	1/4" FNPT x Male QD Brass
							10-0678	1/4" FNPT x Female Stainless Steel
							10-0679	1/4" FNPT x Male Stainless Steel
							10-0830	1/4" MNPT x Male Straight Thru
							10-0831	1/4" FNPT x Male Straight Thru
							10-0833	1/4" FNPT x Female Straight Thru
							10-1386	1/8" FNPT x Female QD Brass
							10-1387	1/8" FNPT x Male QD Brass

Fittings / Bushings / Ells / Nipples					Order #	Description
					10-1045	45° Ell MxF NPT, Brass 1/8"
					10-0042	45° Ell MxF NPT, Brass 1/4"
					10-2517	Brass Nipple, Thick Wall MxM 1/4"
					10-0056	Chrome Nipple, Thick Wall MxM 1/4"
					10-2517	Brass Plug, Insert Hex, 1/4-18 NPT
					10-2518	Brass Plug, Insert Hex, 3/8-18 NPT
					10-2525	Brass 1/4" Barb x 3/8-18 NPT
					10-2526	Brass 1/4" Barb x 1/4-18 NPT
					10-2527	Brass 1/2" Barb x 1/4-18 NPT
					10-2528	Brass 1/2" Barb x 3/8-18 NPT
					10-2532	Brass Adapter, 1/4" M x 3/8" F
					10-2536	Brass Coupler 3/8" F x 1/4" F NPT
					10-2539	Brass Tee, 1/4" FxFxM NPT
					10-0705	Brass Swivel 1/4" MxF NPT
					10-2526	
					10-2528	

Portable Components and Accessories					Order #	Description
					20-0582 / 20-0581	SS Shelf 48" Wide 3 Tiers
					20-0687	SS Box Holder 10" for 5 Gallon Jug
					20-0537	Drain Fitting
					20-0577	Gate Valve, 1.5" Slip x Slip ABS
					20-0578	Gate Valve, 1.5" Male x Slip ABS
					20-0579	Gate Valve Gasket Thick (1.50")
					20-0580	Gate Valve Nut, Threaded (1.50")
					20-0581	Seal for Gate (2 required)
					20-0582	Seal Kit, Carded, w/Nuts and Bolts
					20-0600	Cord, 12 Guage x 3 Wire 25'
					20-0607	Guage, SS Dampened 2.5" 0-1000 PSI
					20-0653	Unloader, 450-500 PSI,
					20-0663	1/2" Filter BxB
					20-0664	Drain Spout for Gate Valve
					20-0380	Priming Valve
					20-0537	
					20-0580	
					20-0380	
					20-0579	
					20-0607	

## CHOOSE THE RIGHT NOZZLE

### How to read nozzle numbers:

Nozzles used on wands have a set of 4, 5, or 6 numbers which give information about flow and spraying angle. The first two or three numbers indicate the spray angle, listed normally as 80, or 95, or 110 are used with carpet cleaning, but other angles, such as 05 or 25, are available also.

The second group of numbers (the last 2-3 numbers), indicate the flow that will pass through each nozzle. Numbers such as 015, 02, and 03 are common numbers.

### How to read nozzle sizes, angle of spray:

The first 2 or 3 numbers in the Nozzle ID indicate the angle in degrees at 40 PSI.

Size	Angle @ 40 PSI	Angle @ 200 PSI
110	110°	122°
95	95°	111°
80	80°	90°
65	65°	79°

### How to read nozzle sizes, flow:

The last 2 or 3 numbers in the Nozzle ID indicate the nozzle size in Gallons Per Minute at 40 PSI. Note that at higher pressure the flow increases.

Size	Flow @ 40 PSI	Flow @ 200 PSI	Flow @ 600 PSI
01	0.1 gpm	0.2 gpm	0.4 gpm
015	0.15 gpm	0.3 gpm	0.6 gpm
02	0.2 gpm	0.4 gpm	0.8 gpm
03	0.3 gpm	0.6 gpm	1.2 gpm
05	0.5 gpm	1.0 gpm	2.0 gpm

### Examples:

110015 = 110° 0.15gpm      11003 = 110° 0.3gpm  
 9502 = 95° 0.2gpm      8003 = 80° 0.3gpm  
 6506 = 65° 0.6gpm

## DISTANCE FROM NOZZLE AND NOZZLE ANGLE

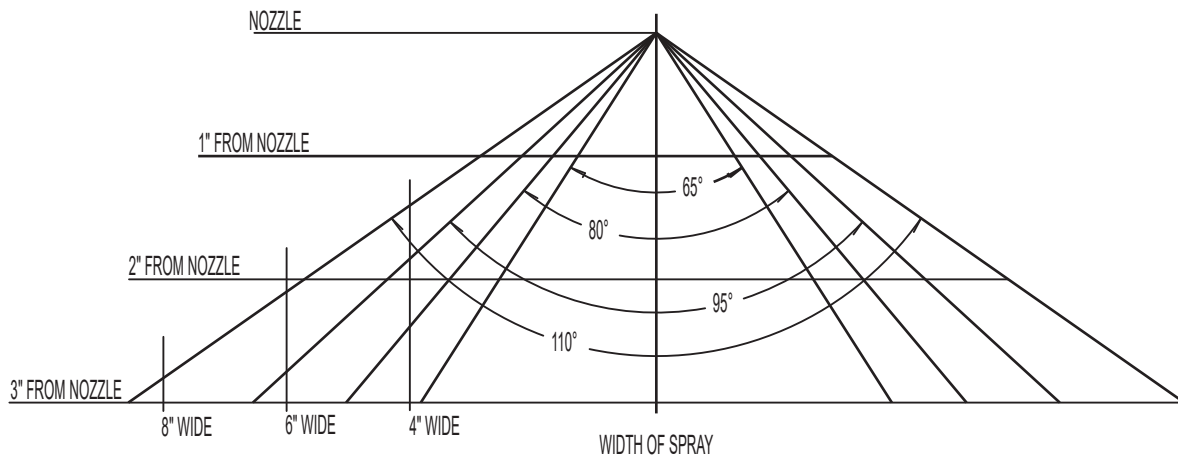



The chart above is useful to verify that you are using the right angle nozzle on your wand. Find the angle of nozzle that you are using, measure the distance to the vacuum opening. Check to see if you have the width of coverage that you need. Replace nozzle as needed to get the proper coverage and proper flow. Typically, most 4 jet wands should have 95015 or 110015 nozzles.

Remember that the correct size nozzle will provide good coverage, keeping heat in the solution for better cleaning and faster solution removal for dryer carpets.



**Nozzles**

Brass TJet	Order #	Description	Angle	Flow
	10-0267	50015 TJet Tip	50	015
	10-0269	6505 TJet Tip	65	05
	10-0610	6506 TJet Tip	65	06
	10-0270	8001 TJet Tip	80	01
	10-0605	8002 TJet Tip	80	02
	10-0271	8003 TJet Tip	80	03
	10-0606	8004 TJet Tip	80	04
	10-0272	8006 TJet Tip	80	06
	10-0974	95015 TJet Tip	95	015
	10-0914	9502 TJet Tip	95	02
	10-0612	9503 TJet Tip	95	03
	10-0915	9504 TJet Tip	95	04
	10-0879	11001 TJet Tip	110	01
	10-0608	110015 TJet Tip	110	015
	10-0607	11002 TJet Tip	110	02
	10-0916	11003 TJet Tip	110	03
	10-0273	11004 TJet Tip	110	04

Brass 1/8" VJet	Order #	Description	Angle	Flow
	10-0613	0502 VJet Nozzle	05	02
	10-0874	1501 VJet Nozzle	15	01
	10-0875	15015 VJet Noz.	15	015
	10-0873	8001 VJet Nozzle	80	01
	10-0617	80015 VJet Noz.	80	015
	10-0876	8002 VJet Nozzle	80	02
	10-0618	8003 VJet Nozzle	80	03
	10-0816	9501 VJet Nozzle	95	01
	10-0619	95015 VJet Noz.	95	015
	10-0923	9502 VJet Nozzle	95	02
	10-0290	9503 VJet Nozzle	95	03
	10-0623	9504 VJet Nozzle	95	04
	10-0625	9505 VJet Nozzle	95	05
	10-0818	11001 VJet Noz.	110	01
	10-0633	110015 VJet Noz.	110	015
	10-0631	11002 VJet Noz.	110	02
	10-0626	11003 VJet Noz.	110	03
10-1121	11006 VJet Noz.	110	06	

SS TJets	Order #	Description	Angle	Flow
	10-0277	9501 TJet Tip	95	01
	10-0280	11001 TJet Tip	110	01
	10-0281	110015 TJet Tip	110	015
	10-0282	11002 TJet Tip	110	02
	10-0283	11003 TJet Tip	110	03

SS 1/8" VJet	Order #	Description	Angle	Flow
	10-0970	9501 VJet Nozzle	95	01
	10-0820	95015 VJet Noz.	95	015
	10-0925	9502 VJet Nozzle	95	02
	10-0291	9503 VJet Nozzle	95	03
	10-0292	9504 VJet Nozzle	95	04
	10-0293	9506 VJet Nozzle	110	01
	10-0972	11001 VJet Noz.	110	01
	10-0821	110015 VJet Noz.	110	015
	10-0926	11002 VJet Noz.	110	02
	10-0296	11003 VJet Noz.	110	03
	10-0297	11004 Nozzle	110	04

Brass 1/4" VJet	Order #	Description	Angle	Flow
	10-0628	6506 VJet Nozzle	65	06
	10-0983	8001 VJet Nozzle	80	01
	10-0286	8002 VJet Nozzle	80	02
	10-0289	8006 VJet Nozzle	80	06
	10-0611	9501 VJet Nozzle	95	01
	10-0917	95015 VJet Noz.	95	015
	10-0815	9502 VJet Nozzle	95	02
	10-0629	9503 VJet Nozzle	95	03
	10-0624	9505 VJet Nozzle	95	05
	10-0920	11001 VJet Noz.	110	01
	10-0919	110015 VJet Noz.	110	015
	10-0921	11002 VJet Noz.	110	02
	10-0814	11003 VJet Noz.	110	03
	10-0929	11004 VJet Noz.	110	04
	10-1119	11005 VJet Noz.	110	05
10-1120	11006 VJet Noz.	110	06	

Filters/Holders	Order #	Description
	10-0582	Inline Filter Assembly
	10-0584	TJet Holder w/Filter & Chk Valve
	10-0585	Inline Filter w/Check Valve
	10-0586	T-Jet Holder w/Filter
	10-0590	Brass Filter Body (no Mesh Filter)
	10-0592	100 Mesh Internal Filter
	10-0593	100 Mesh Filter w/Check Valve

SS 1/4" VJet	Order #	Description	Angle	Flow
	10-0927	9501 VJet Nozzle	95	01
	10-0918	95015 VJet Noz.	95	015
	10-0973	11001 VJet Noz.	110	01
	10-0822	110015 VJet Noz.	110	015
	10-0632	11002 VJet Noz.	110	02
	10-0812	11003 VJet Noz.	110	03

Check Valves	Order #	Description
	10-0587	1/8" Check Valve 1/2" Extender
	10-0588	1/8" Check Valve 1" Extender
	20-0390	1/4" Check Valve 1" Extender
	10-1116	1/8" Stubby Check Valve

Additional Nozzles Available Upon Request



**WESTPAK QUICK REFERENCE GUIDE**

<b>Part #</b>	<b>Tube Size</b>	<b>Head Width</b>	<b>Jets</b>	<b>Jet Size</b>		<b>Valve</b>	<b>PSI Rating</b>	<b>Length</b>	<b>Weight Lbs.</b>	<b>Page #</b>
<b>1.50" TM &amp; High Pressure Portables Wands</b>										
10-1420	1.25"	10"	1	11003	1/4"	20-0030	1200	32"	6.0 Lbs	3
10-1428	1.50"	12"	1	11003	1/4"	20-0030	1200	32"	6.0 Lbs	3
10-0761	1.50"	12"	2	11003	1/8"	20-0030	1200	62"	6.8 Lbs	3
10-0780	1.50"	12"	1	11003	1/4"	20-0030	1200	62"	7.7 Lbs	3
10-0795	1.50"	12"	2	11003	1/8"	20-0030	1200	62"	7.8 Lbs	3
10-0762	1.50"	12"	2	9503	1/4"	20-0030	1200	62"	7.7 Lbs	3
10-1455	1.50"	12"	2	11002	TJet	20-0030	1200	62"	7.6 Lbs	3
10-0530	1.50"	12"	2	11003	1/4"	20-0030	1200	62"	7.4 Lbs	3
10-0070	1.50"	12"	4	95015	1/8"	20-0030	1200	62"	8.2 Lbs	4
10-0556	1.50"	14"	4	95015	1/8"	20-0030	1200	62"	9.2 Lbs	4
<b>Blaster Hard Surface Wands</b>										
10-1542	1.50"	14"	4	110015	1/8"	20-0030	1200	59"	9.0 Lbs	6
10-1544	1.50"	14"	4	110015	1/8"	20-0030	1200	59"	9.2 Lbs	6
10-1543	1.50"	N/A	N/A	N/A	N/A	20-0030	1200	59"	7.0 Lbs	6
10-1535	1.50"	6"	1	65015	1/8"	20-0030	1200	59"	7.6 Lbs	6
<b>1.75" &amp; 2.00" TM &amp; High Pressure Portables Wands</b>										
10-0535	1.75"	12"	4	95015	1/8"	20-0030	1200	63"	9.4 Lbs	5
10-0549	1.75"	14"	4	95015	1/8"	20-0030	1200	63"	9.6 Lbs	5
10-0755	2.00"	12"	4	95015	1/8"	20-0085	1500	63"	9.8 Lbs	5
10-0550	2.00"	14"	4	95015	1/8"	20-0085	1500	63"	9.8 Lbs	5
10-0750	2.00"	14"	4	95015	1/8"	20-0085	1500	63"	10.2 Lbs	5
<b>Titanium Wands (include Check Valves, SS Nozzles, and Inline Filter)</b>										
10-5070	1.50"	12"	4	95015	1/8"	20-0085	1500	62"	6.0 Lbs	3
10-5755	2.00"	12"	4	95015	1/8"	20-0085	1500	62"	6.0 Lbs	3
10-5550	2.00"	14"	4	95015	1/8"	20-0085	1500	62"	6.8 Lbs	3
10-5750	2.00"	14"	4	95015	1/8"	20-0085	1500	62"	7.7 Lbs	3
<b>Detail and Stair Tools</b>										
10-0504	1.50"	4"	1	9502	1/8"	20-0001	1200	11"	1.6 Lbs	7
10-0506	1.50"	4"	1	9502	1/8"	20-0001	1200	11"	1.7 Lbs	7
10-0520	1.50"	4"	1	9502	1/8"	20-0001	1200	11"	1.6 Lbs	7
10-0521	1.50"	4"	1	9502	1/8"	20-0001	1200	11"	1.6 Lbs	7
10-0524	1.50"	4"	1	9502	1/8"	20-0001	1200	11"	1.6 Lbs	7
10-0498	1.50"	2"	1	80015	1/8"	20-0001	1200	18"	1.9 Lbs	7
10-1322	1.50"	6"	2	9502	1/8"	20-0001	1200	14"	2.5 Lbs	7
10-0564	1.50"	10"	2	9503	1/4"	20-0030	1200	40"	6.2 Lbs	8
10-0771	1.50"	10"	2	9503	1/4"	20-0030	1200	29"	5.5 Lbs	8
10-0772	1.50"	10"	2	9503	1/4"	20-0001	1200	18"	4.2 Lbs	8
10-1320	1.50"	6"	2	9502	1/4"	20-0030	1200	18"	3.8 Lbs	8
10-1321	1.50"	6"	2	9502	1/4"	20-0030	1200	24"	4.2 Lbs	8
<b>Hard Surface and Sprayers</b>										
20-0440	1.75"	12"	2	0502	1/8"	20-0085	1500	52"	16 Lbs	9
20-0444	1.50"	6"	2	0502	1/8"	20-0085	1500	10"	4.3 Lbs	9
10-0507	N/A	N/A	1	6506	1/4"	20-0030	400	N/A	3.8 Lbs	10
10-0518	N/A	N/A	1	6506	1/4"	20-0022	400	N/A	4.4 Lbs	10



# **CARPET & HARD SURFACE TOOLS**



**866-972-5777**



**CARPET CLEANING TOOLS & ACCESSORIES  
YOUR ONE STOP SHOP!**